

# HAVU TASO 135



**Kaikissa tuotteita koskevissa yhteydenotoissa on ilmoitettava pakkausetiketin sarjanumero.**

## Puhdistaminen

Pehmeällä kankaalla tai paperilla ja lievästi emäksisellä puhdistusaineella. Vaikeimmat tahrat voidaan poistaa alkoholia sisältävällä puhdistusaineella.

## Materiaali-info

Standardin EN 312:2003 vaatimukset täyttävä kalustelevy.  
Formaldehydiluokka: Class E1 EN 312:2003  
Pintamateriaaliluokitus: M1 rakennusmateriaalin päästöluokka.

## Valmistaja

Rintaluoma Oy  
Huonekalutehdas  
www.rintaluoma.fi

## Yhteydenotot ja kysymykset

Rintaluoma Oy  
email: asiakaspalvelu@rintaluoma.com

 Seuraa meitä Instagramissa @rintaluomafi



Säilytä sarjanumero  
pakkausetiketistä!



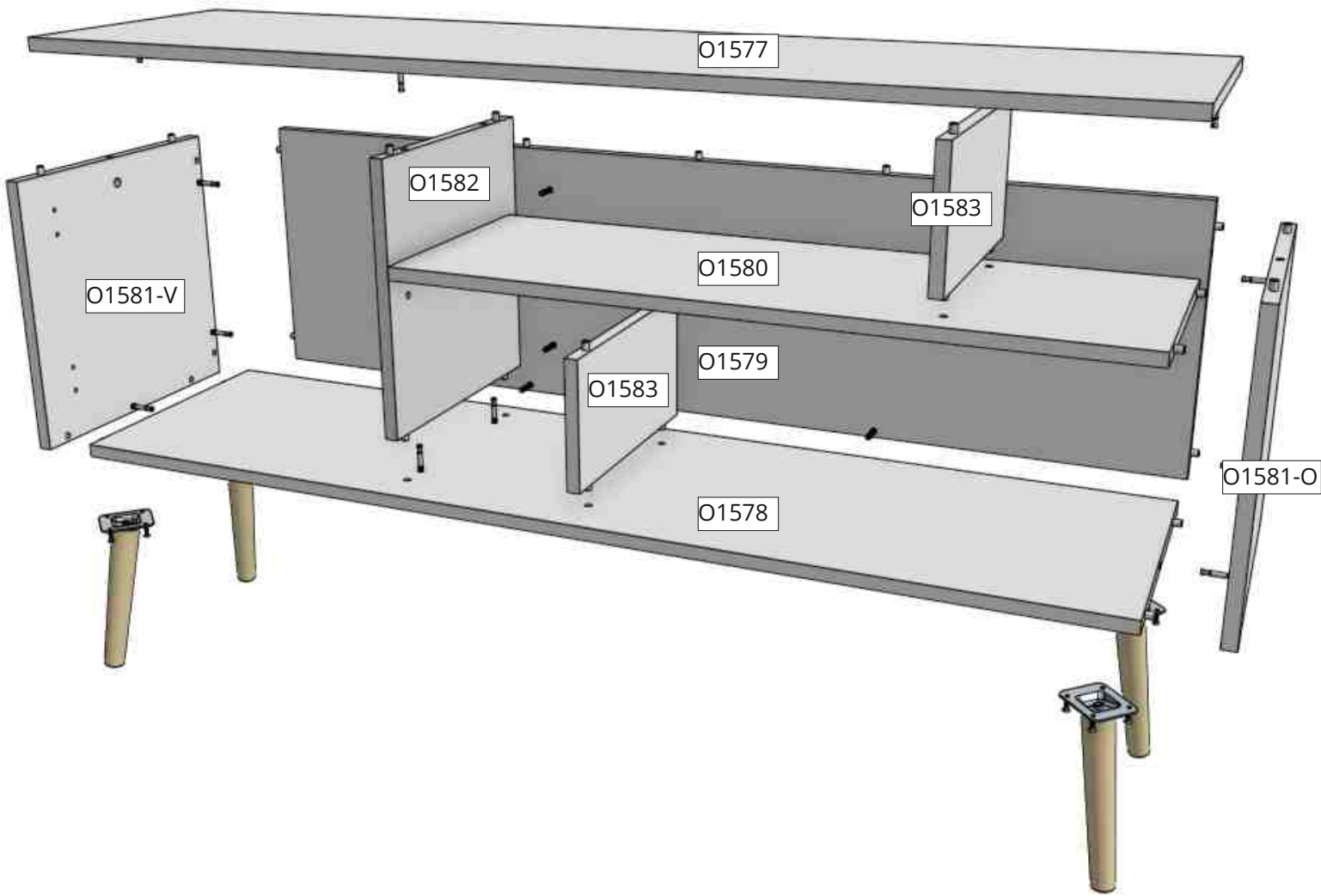

12x  
H1044-1



12x  
H1044-2



10x  
H1136



1x  
H1051

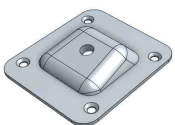

4x  
H1143



4x  
H1144



16x  
3,5x15  
H1033



1x  
H1173

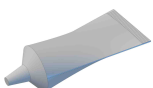

1x  
H1092



4x  
H1139



4x 7x50  
H1155



1x  
M4x20  
H1046

1

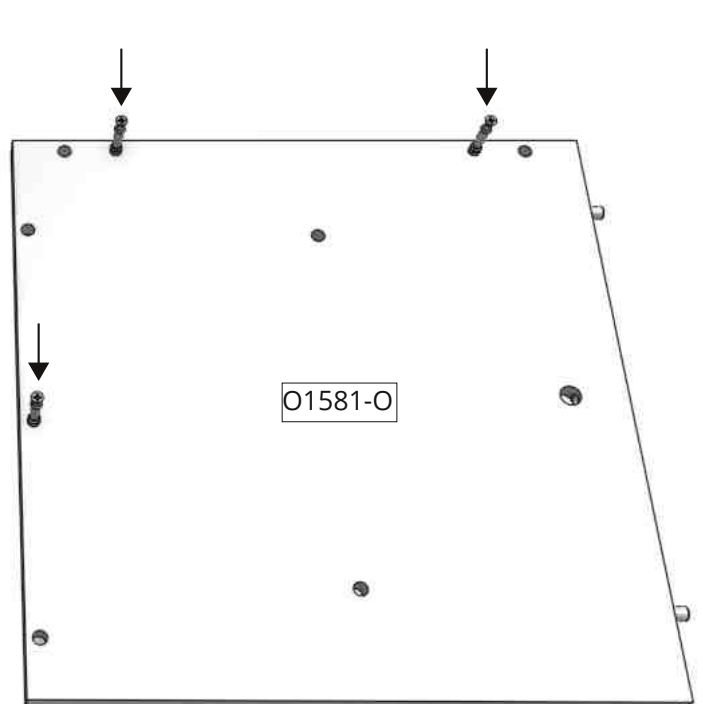
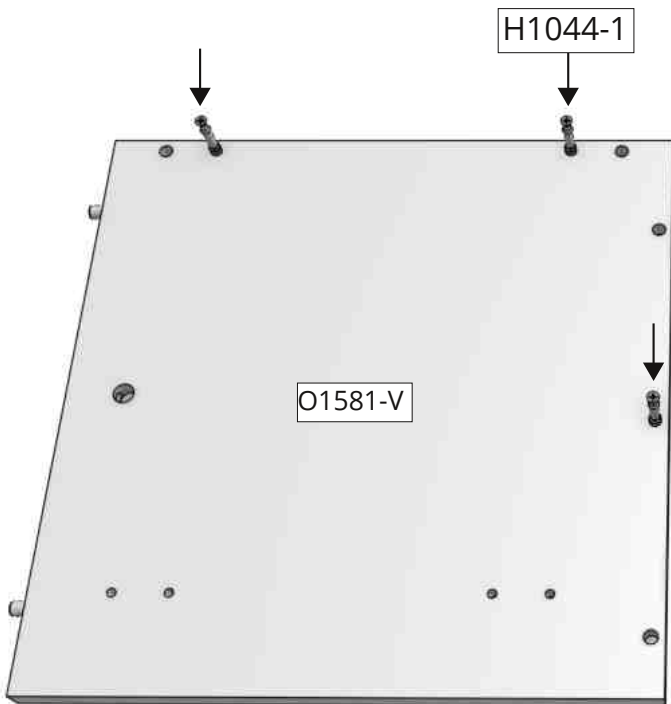
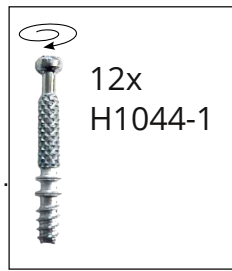
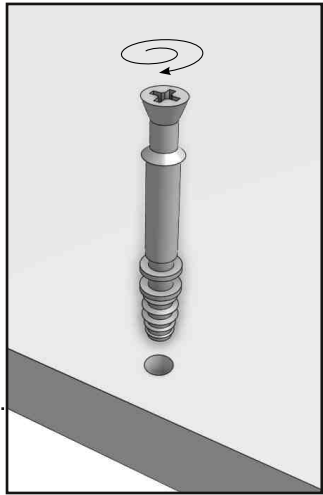
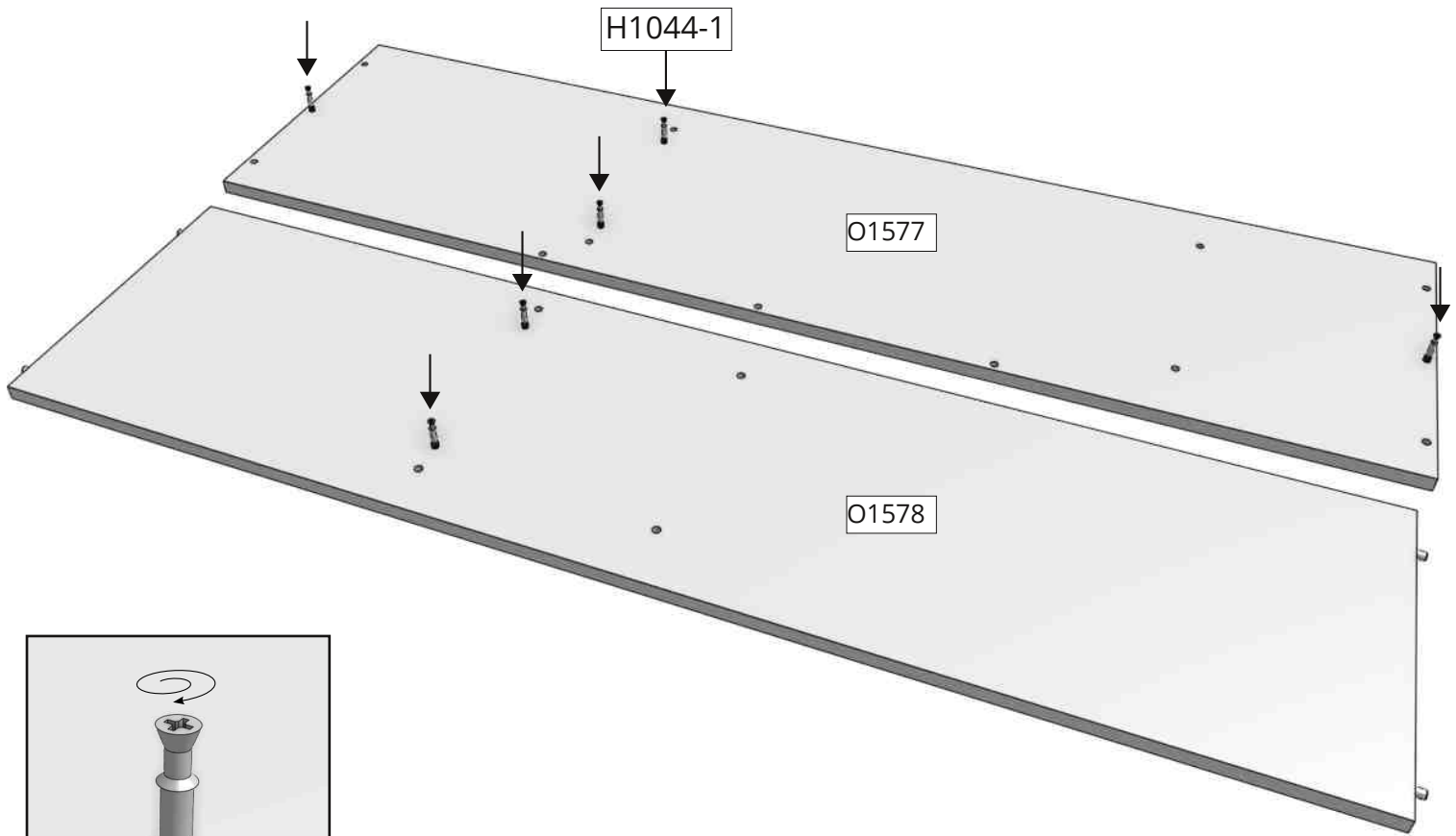

2

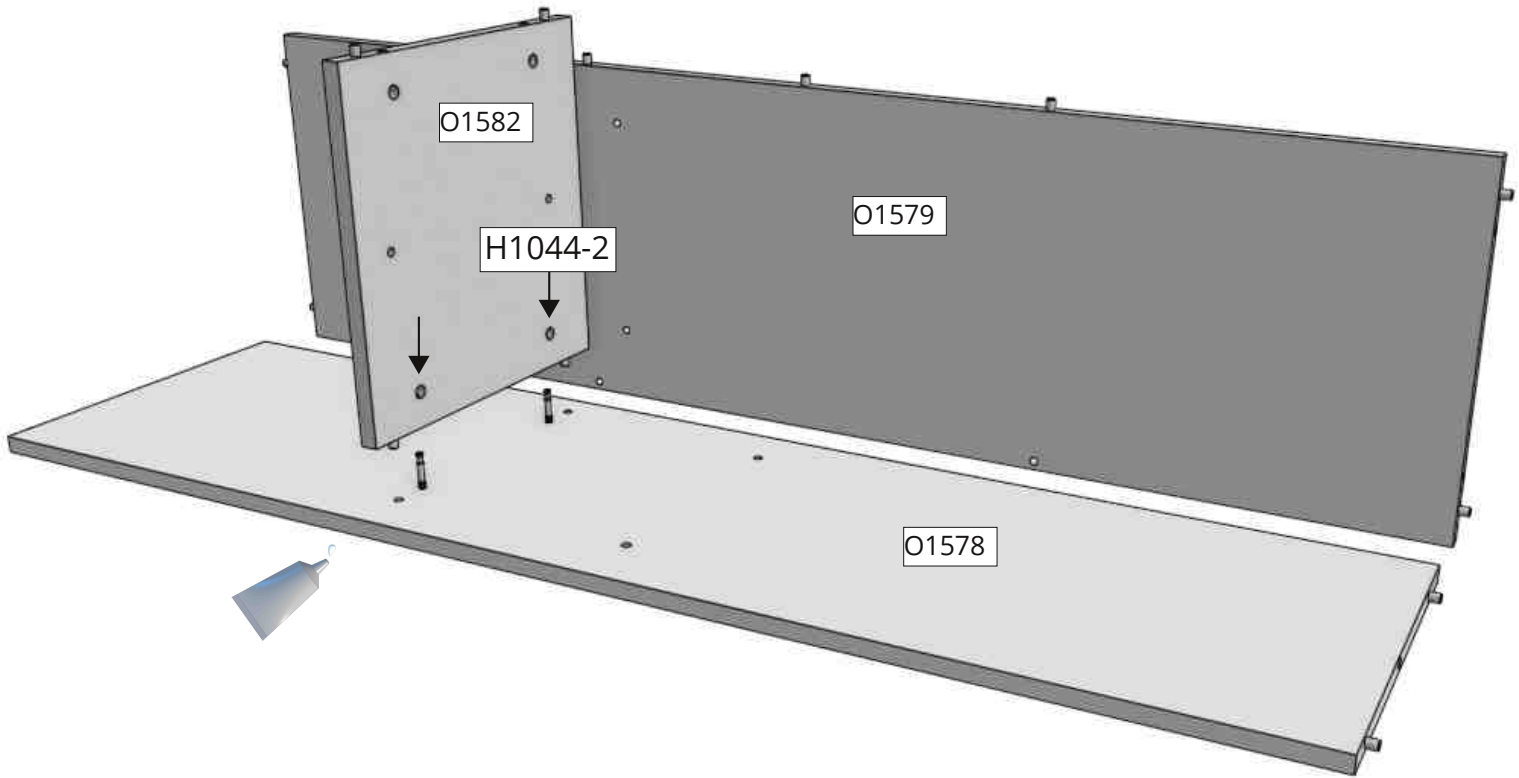

Minifix (H1044-1 & H1044-2)

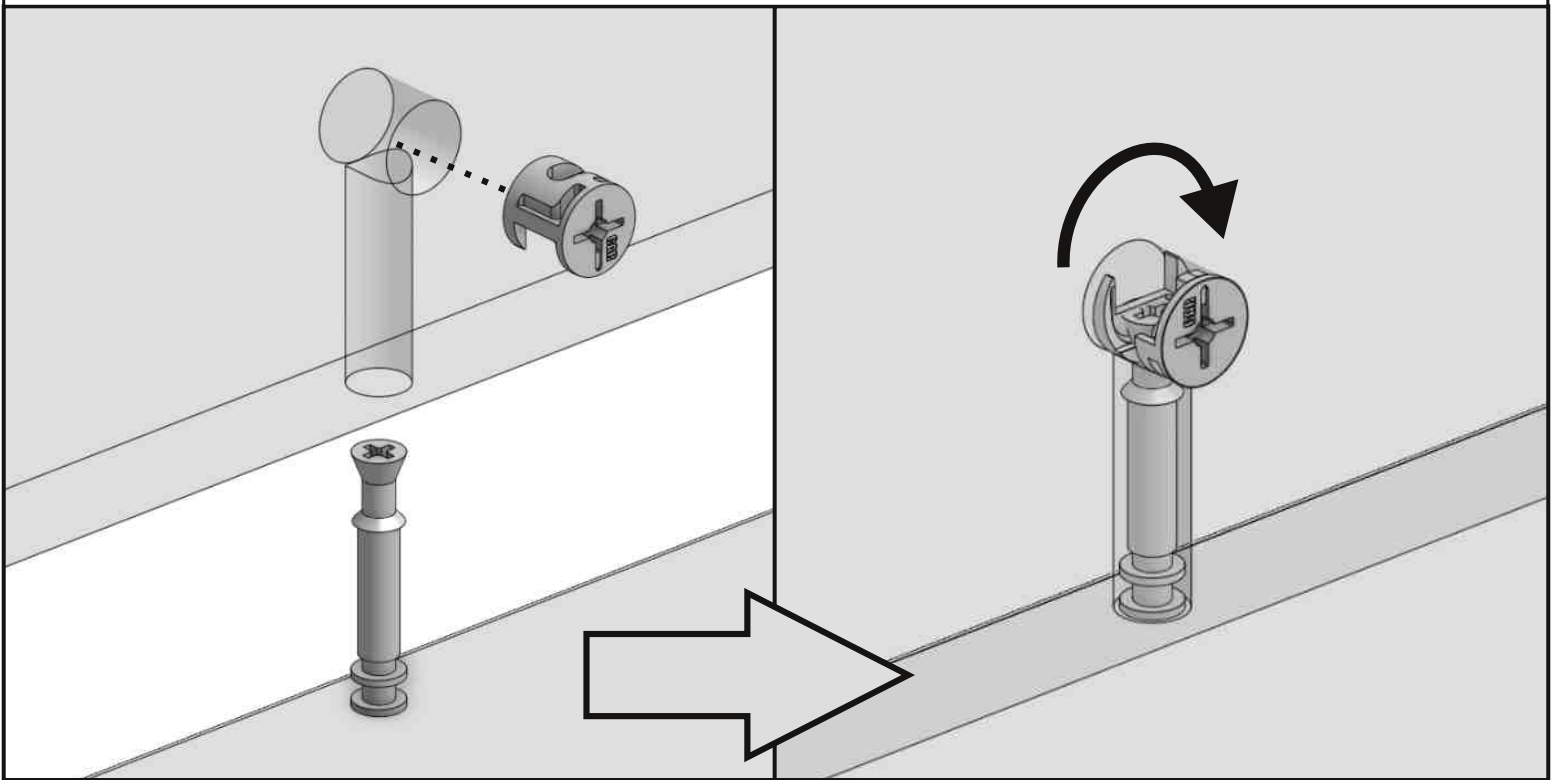

# 3

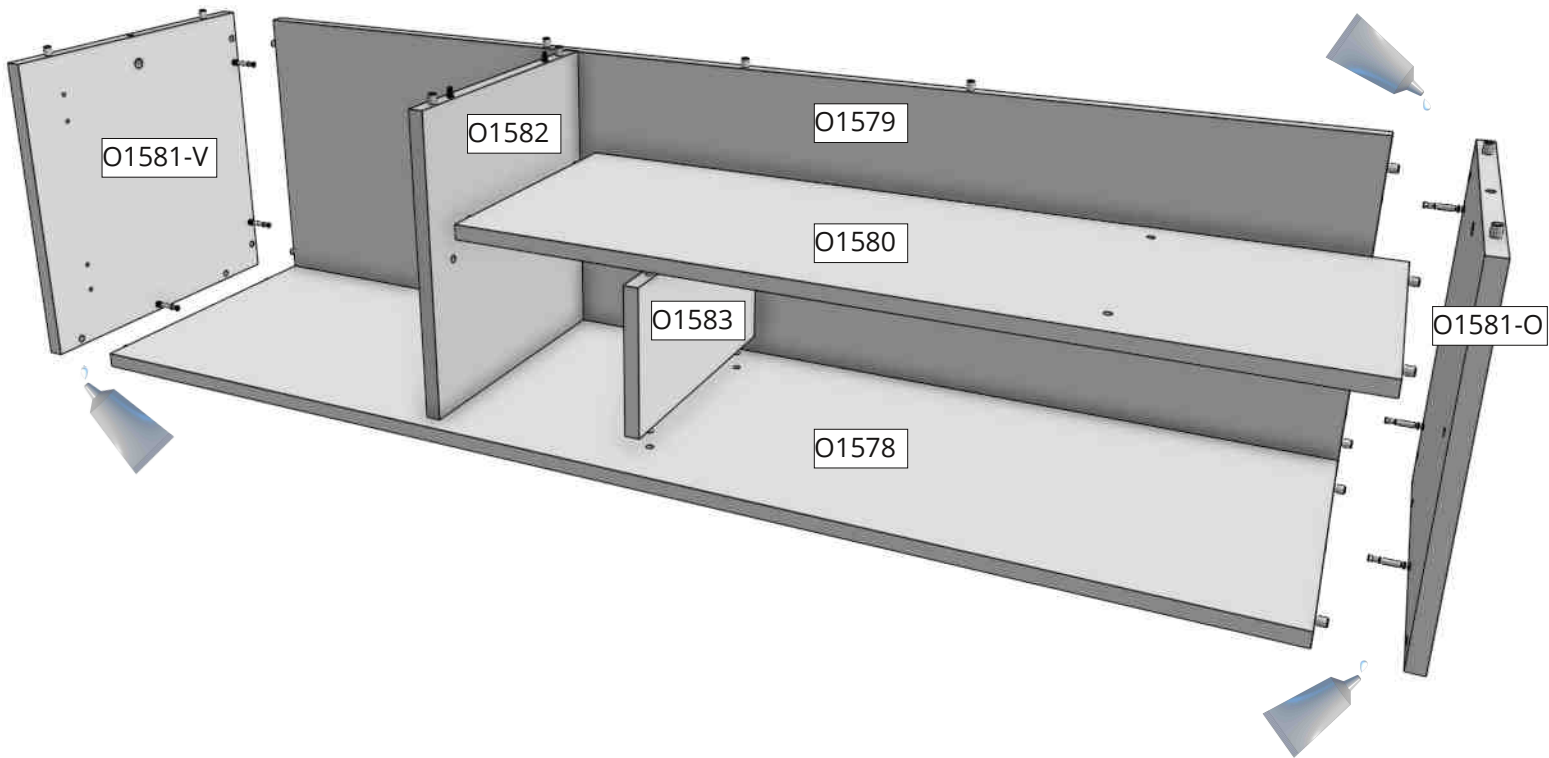

# 4

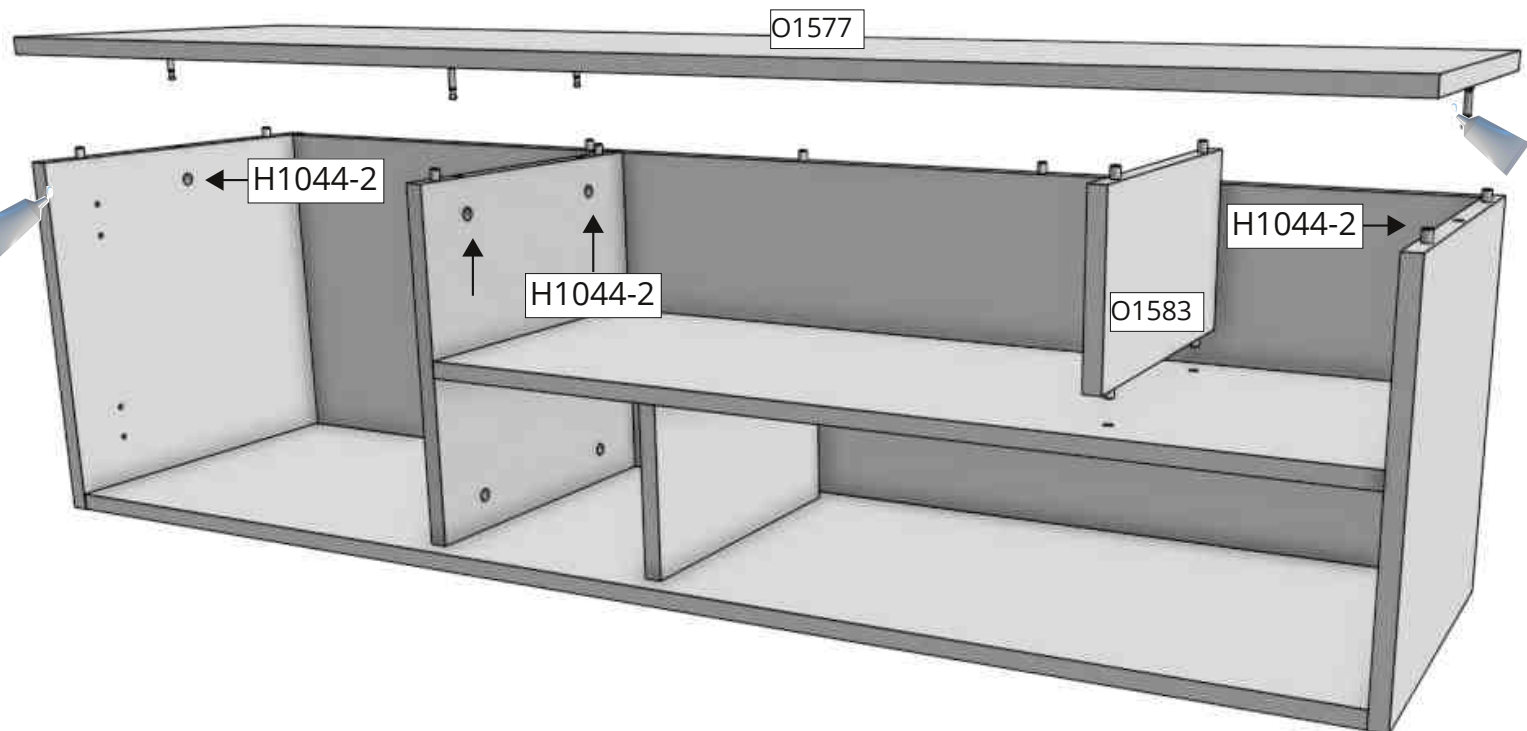
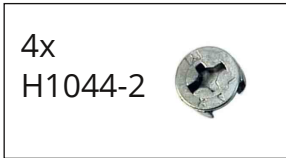

5

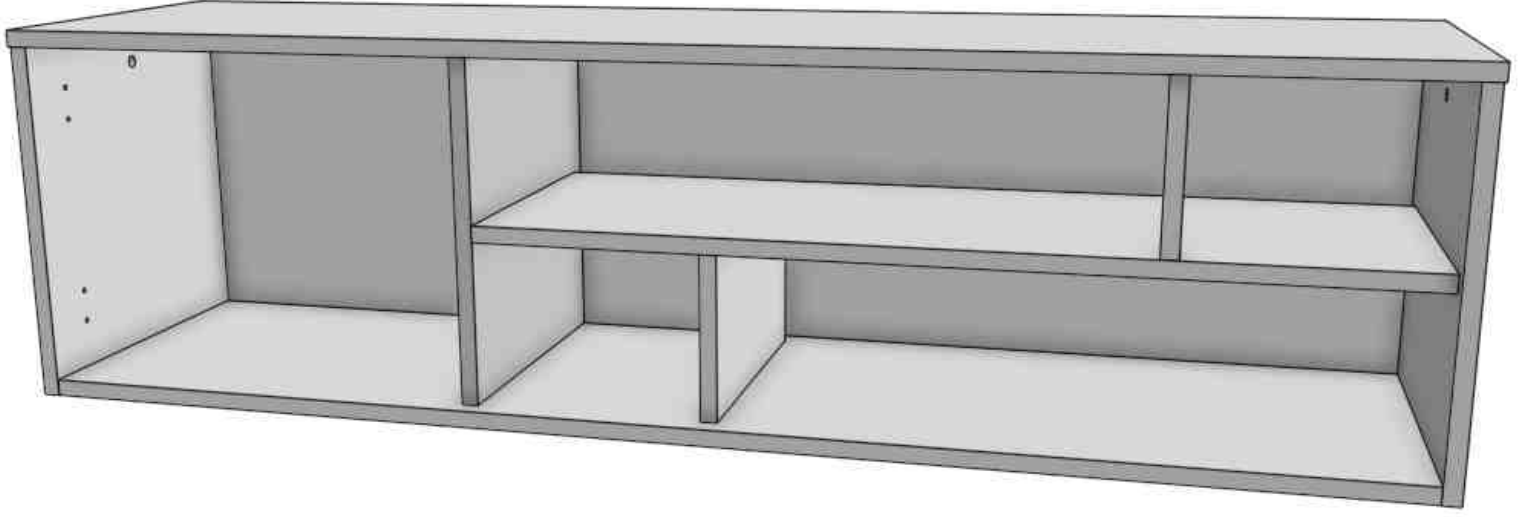

6x  
H1044-2

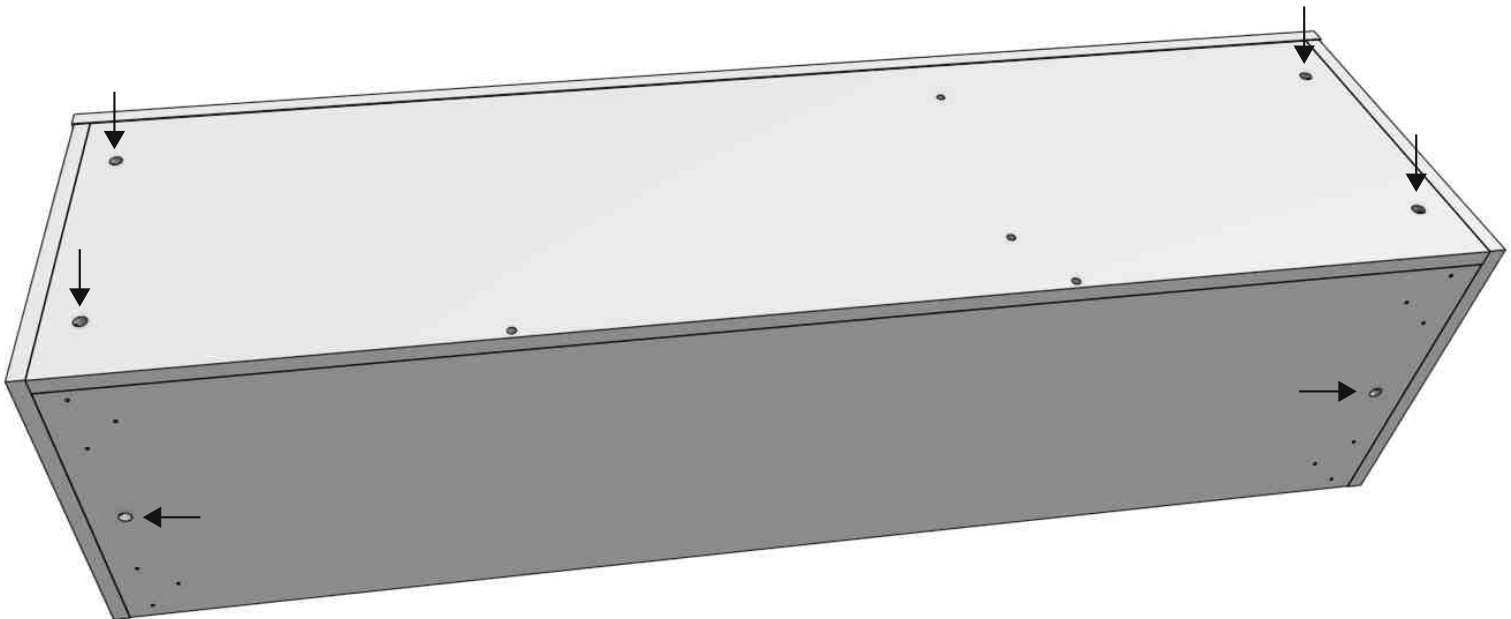

6

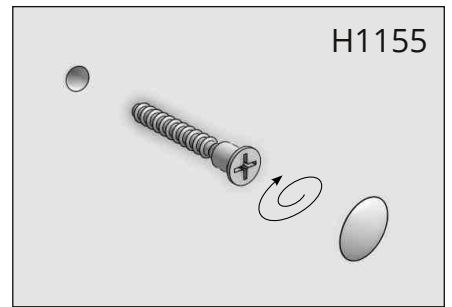
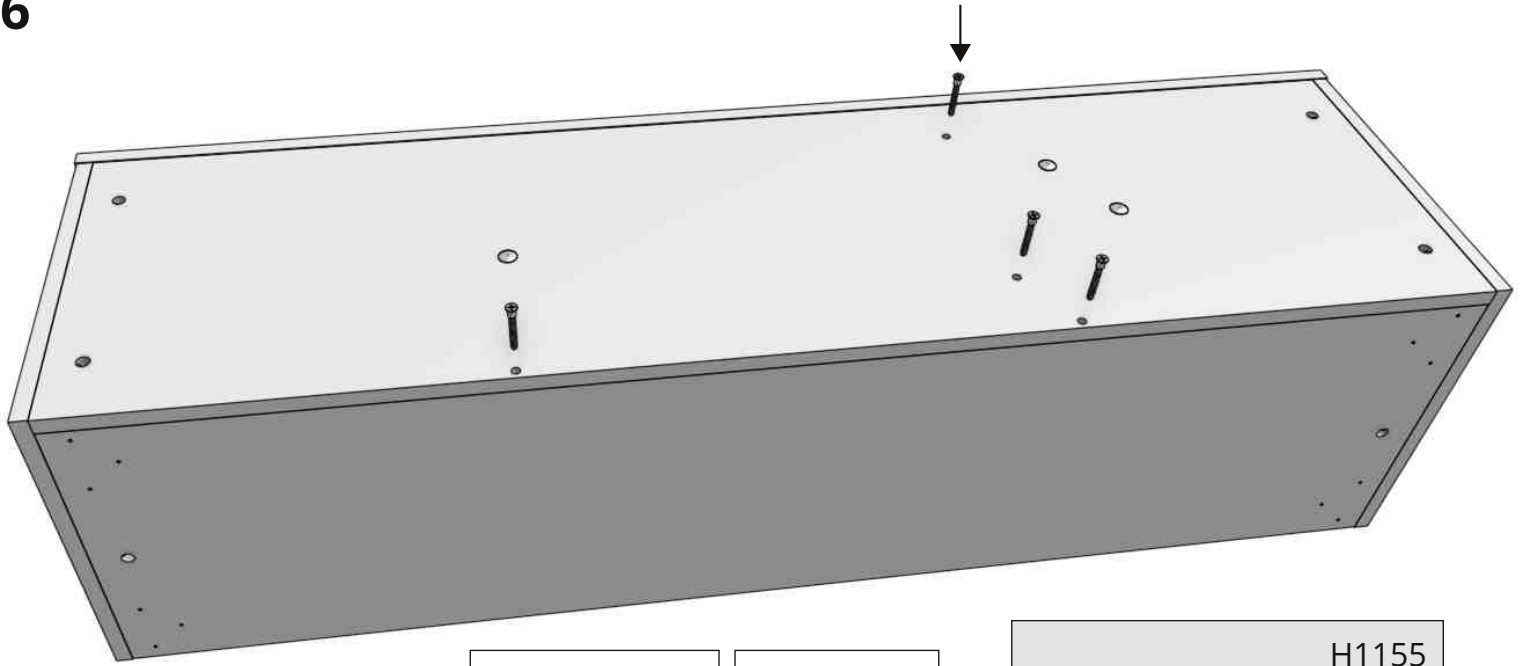

7

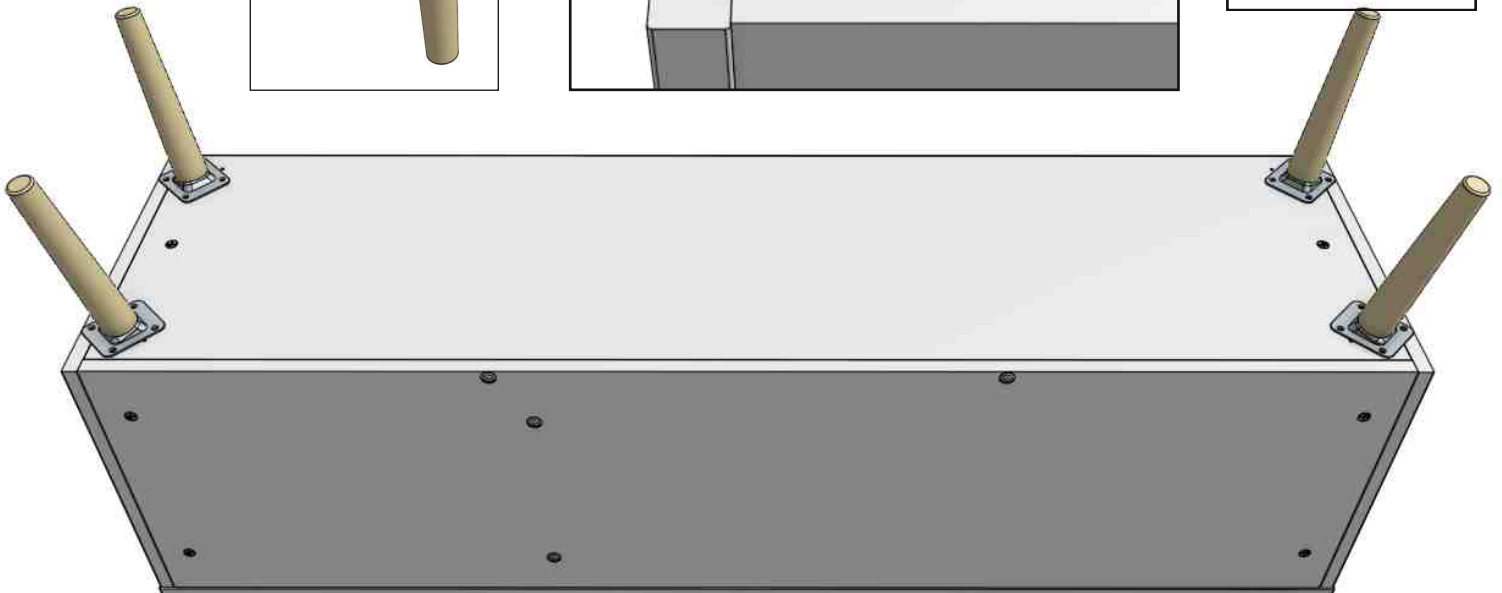
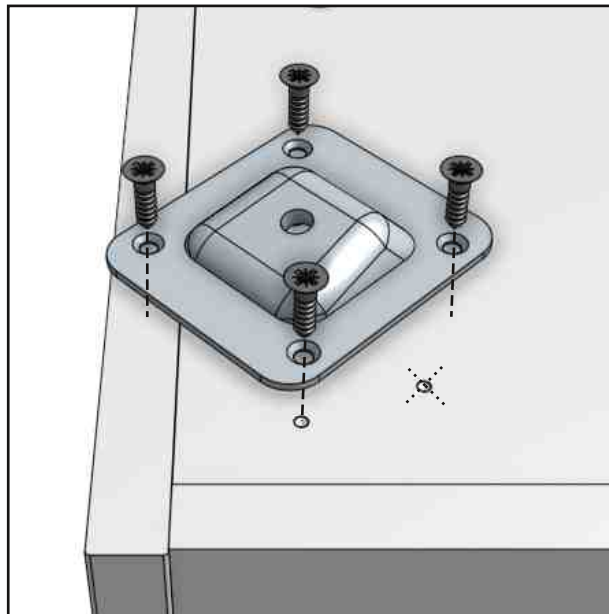
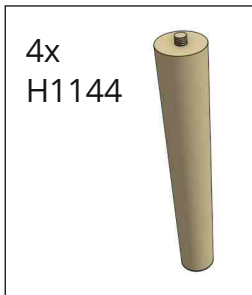

8

1x  
H1051

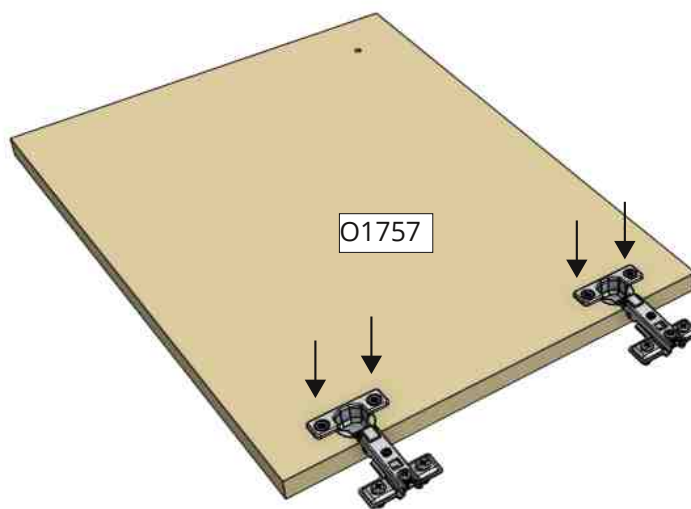
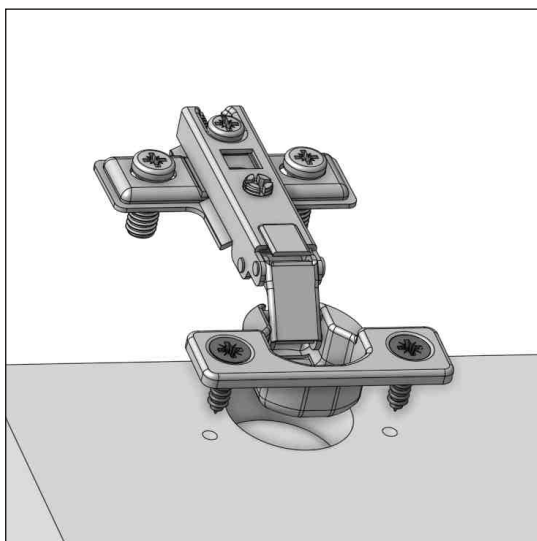

**Säätö pystysuunnassa:**

Avaa kaikkien saranoiden kiinnitysruuveja (1).  
Nosta tai laske ovea ja kiristä ruuvit huolellisesti

**Säätö syvyysuunnassa:**

Avaa lukitusruuvia (2).  
Korjaa oven asentoa.  
Kiristä lukitusruuvi (2).

**Säätö vaakasuunnassa tai kallistus:**

Avaa lukitusruuvia (2).  
Korjaa oven asentoa säätöruuvista (3).  
Kiristä lukitusruuvi (2).

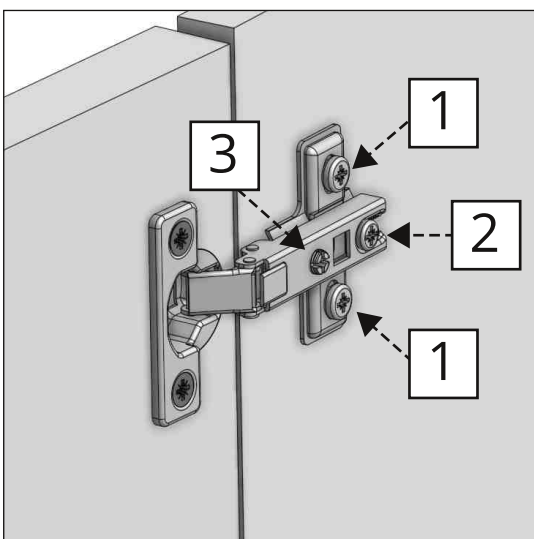

**Vertikal justering:**

Öppna alla gångjärnens fästskruvar (1).  
Höj eller sänk dörren och spänn fast skruvarna.

**Justera djupled:**

Öppna låsskruven (2).  
Korrigera dörrens position.  
Spänn fast låsskruven (2).

**Horisontell justering:**

Öppna låsskruven (2).  
Korrigera dörrens position med justeringsskruv (3).  
Spänn fast låsskruven (2).

1x  
H1173



1x  
M4x20  
H1046

